



PRE-RINSE UNIT

Z80000-PR3

TAG _____



Engineering Specification: Zurn AquaSpec® Z80000-PR3

Angled self-closing 1.6 GPM [6L] pre-rinse valve with an insulated handle, a stay open ring and an aerated outlet. Unit has a 7/8-20 UNEF threaded male inlet.

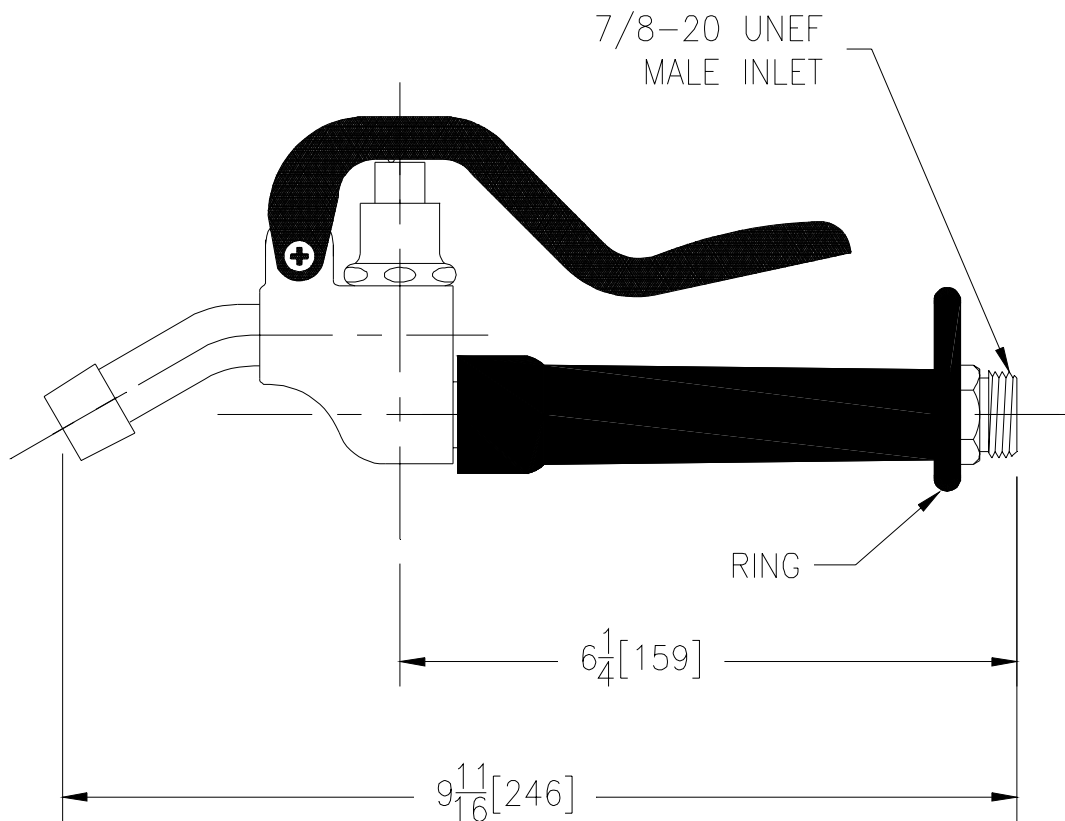

Note: All dimensions are for reference only. Do not use for pre-plumbing.

OPTIONAL ACCESSORIES

No options required.

ZURN INDUSTRIES, INC. ♦ COMMERCIAL BRASS OPERATION ♦ 2640 SOUTH WORK STREET ♦ FALCONER NY 14733

Phone: 1-716-665-1132 ♦ Fax: 1-716-665-1135 ♦ World Wide Web: www.zurn.com

In Canada: ZURN INDUSTRIES LIMITED ♦ 3544 Nashua Drive ♦ Mississauga, Ontario L4V1L2 ♦ Phone: 905/405-8272 Fax: 905/405-1292