

ESD-20080

► **Description**

AC Powered, Sensor Activated, Electronic Soap Dispenser with AC Powered, Sensor Activated Electronic Hand Washing Faucet for tempered or hot/cold water operation.

► **Model**

ESD-20080 Plug-in Transformer Powered Faucet and Soap Dispenser

► **Faucet Flow Rate**

0.5 gpm/1.9 Lpm Vandal Resistant Spray Head
 (See **Accessories** for other Spray Head options)

► **Faucet Specifications**

ADA Compliant, Sensor Activated, 24 VAC, Chrome Plated Cast Brass Hand Washing Faucet with the following features:

- Splash-proof Circuit Control Module
- Bak-Chek[®] Tee for Hot/Cold Supply
- Vandal Resistant Spray Head with Pressure Compensating Flow Control
- Sensor Range Adjustment Screw
- Troubleshooting LED Indicator Lights
- User Friendly Variable Time Out Settings
- Serviceable Filtered Solenoid Valve
- 120 VAC/24 VAC Plug-in Transformer (P Type ETF-233 - Standard)
- Metal Jacketed Wire Protection for Sensor/Solenoid Leads
- Modular Quick-Release Sensor and Solenoid Connections
- Trim Plate with Anti-rotation Pin (4" Trim Plate - Standard)

► **Soap Dispenser Specifications**

ADA Compliant, Sensor Activated, Electronic, Chrome Plated Cast Brass Spout, Soap Dispenser with the following features:

- Modular One-piece Construction
- Active Infrared Sensor
- 120 VAC/6 VDC Plug-in Transformer (P Type ESD-227 - Standard)
- Mounting Hardware included
- Low Soap Level Indicator
- Easy Loading Disposable Soap Refills
- New Pump and Delivery Tube with each Refill

Unit supplied with one 800 ml. Container of Soap.

► **Variations**

ESD-25085 DC Powered Faucet and Soap Dispenser

► **Special Finishes**

- PB** Polished Brass (PVD Finish)
- GP** Gold Plate (PVD Finish)
- BN** Brushed Nickel (PVD Finish)
- SF** Satin Chrome

► **Accessories** (Specify separately)

• **Faucet Transformers**

- EL-248-40** 120 VAC/24 VAC, 50/60 Hz (40 VA) — Box Mount (will operate up to 2 faucets)
- EL-154** 120 VAC/24 VAC, 50/60 Hz (50 VA) — Box Mount (will operate up to 3 faucets)
- EL-208** 120 VAC/24 VAC, 50/60 Hz (100 VA) — Foot Mount (will operate up to 6 faucets)
- EL-342** 240 VAC/24 VAC, 50/60 Hz (50 VA) — Box Mount (will operate up to 3 faucets)

• **Vandal Resistant Faucet Spray Heads**

- ETF-1028-A** 1.5 gpm/5.7 Lpm Laminar Flow Spray Head (recommended for medical applications)

See OPTIMA Faucet and OPTIMA Accessories Sections of the Sloan Catalog for a complete listing of OPTIMA Faucet Accessories and Variations.



► **Features and Benefits**

- “Touch-free” operation improves hand washing hygiene
- Encourages hand washing for improved sanitary protection
- Automatic operation provides water usage savings over other faucet devices
- Economical pre-measured soap dispensing saves soap and money
- Soap refill cartridge is easy to replace and provides a new mechanism and soap path with every replacement
- Flashing “red” light indicates soap replacement required for continuous soap dispensing
- Three-year Warranty (limited)
- Eliminates “untidy and clumsy” refillable containers

► **Soap Refill Cartridges Available**

- *ESD-217* — 800 ml. bottle of Lotion Soap
- *ESD-232* — 1600 ml. bottle of Lotion Soap
- *ESD-231* — 800 ml. bottle of Anti-bacterial Soap
- *ESD-233* — 1600 ml. bottle of Anti-bacterial Soap

► **Made in the U.S.A.**

► **ASME A112.18.1M**



This space for Architect/Engineer approval	
Job Name _____	Date _____
Model Specified _____	Quantity _____
Variations Specified _____	
Customer/Wholesaler _____	
Contractor _____	
Architect _____	

ELECTRICAL SPECIFICATIONS

- ▶ **Faucet Control Circuit**
24 VAC Input/Output, 50/60 HZ, Adjustable Range Time Out Settings, Modular Plugs and Troubleshooting LED Indicators.
- ▶ **OPTIMA® Faucet Sensor Range**
Nominal: 4" - 5" (102 mm — 127 mm)
Adjustable: 1" - 8" (25 mm — 203 mm) — Adjustability dependent upon depth and reflectivity of basin.
- ▶ **Faucet Solenoid Valve**
24 VAC 50/60 Hz with integral Strainer Filter, 3/8" Compression Inlet/Outlet
- ▶ **Time Out Adjustment Settings**
30 seconds — The Faucet Time out Setting determines the maximum time the faucet will run upon continuous detection. The ESD-20080 is factory set at the 30 second time out. Consult factory for time out settings to meet individual application requirements.

- ▶ **Soap Dispenser Control Circuit**
6 VDC — Operates on a 120 VAC Input/6 VDC Output Transformer.
- ▶ **Transformer**
All Sloan Transformers are 50/60 Hz.
Multiple faucets can be powered by a single transformer, provided that the transformer has been properly sized. Allow a minimum of 15 VA of current rating for each faucet being used.
Faucet (Std.): Plug-in ETF-233 120 VAC/24 VAC - 35 VA
Soap Dispenser (Std.): Plug-in ESD-227 120 VAC/6 VDC - 2 VA
- ▶ **Max. Distance Control Module may be Installed from Spout**
With Standard Cable: 12" (305 mm)
- ▶ **Extension Cables (Optional)**
From Sensor to Control Module: From Solenoid Valve to Control Module:
ETF-1005-26 26" (660 mm) ETF-1003-26 26" (660 mm)
ETF-1005-36 36" (914 mm) ETF-1003-48 48" (1219 mm)
ETF-1005-72 72" (1829 mm) ETF-1003-72 72" (1829 mm)
ETF-1005-108 108" (2743 mm) ETF-1003-108 108" (2743 mm)

SOAP REPLACEMENT

When the soap Bottle is empty, a new Bottle must be used. The Bottle furnished with the unit is not designed to be refilled. Altering the Bottle and refilling it with soap will void the warranty of the product.

To Order Replacement Soap Cartridges:

1-866-700-CLEAN (1-866-700-2532)

Or go to our website: www.optimasoap.com

Refills are also available through your local plumbing or janitorial supply distributor.

Soap Refill Cartridges Available

- ESD-217 — 800 ml. bottle of Lotion Soap
- ESD-232 — 1600 ml. bottle of Lotion Soap
- ESD-231 — 800 ml. bottle of Anti-bacterial Soap
- ESD-233 — 1600 ml. bottle of Anti-bacterial Soap

Can also be replaced with TC® OneShot® Soap Bottles listed below.

Description	Sloan® Part No.	TC® OneShot® Stock No.
800 ml. bottle of Lotion Soap	ESD-217	401311
1600 ml. bottle of Lotion Soap	ESD-232	401541
800 ml. bottle of Anti-bacterial Soap	ESD-231	401312
1600 ml. bottle of Anti-bacterial Soap	ESD-233	401542

FAUCET OPERATION

1. A continuous, invisible light beam is emitted from the OPTIMA® sensor.
2. The faucet is activated by placing hands beneath the spray head, thus activating the Solenoid Valve. Tempered water flows for as long as hands continue to stay within the Sensor's range (30 second automatic shut off).
3. When hands are removed, the water flow automatically stops. The faucet is then ready for the next user.



SOAP DISPENSER OPERATION

The user's hands reflect the beam into the sensor receiver activating the pump allowing a single soap application to flow from the spout. A flashing red LED indicates the soap cartridge is low.



ROUGH-IN DIAGRAM

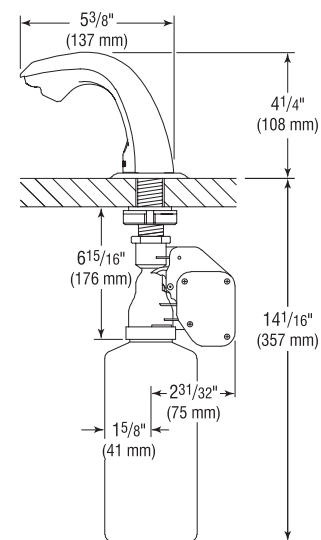
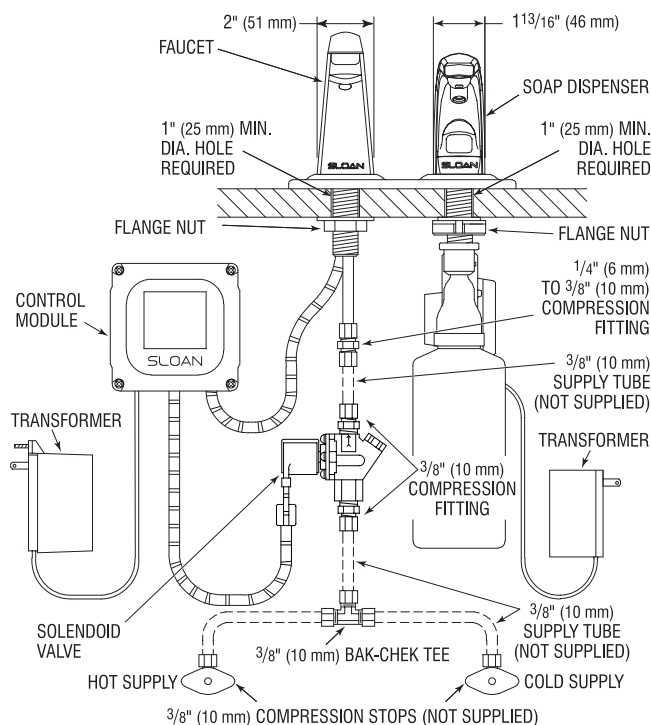
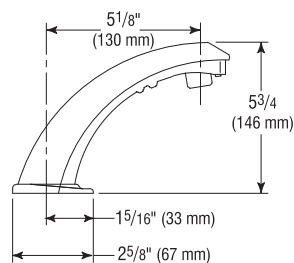

SLOAN VALVE COMPANY • 10500 SEYMOUR AVENUE • FRANKLIN PARK, IL 60131

Phone: 1-800-9-VALVE-9 or 1-847-671-4300 • Fax: 1-800-447-8329 or 1-847-671-4380 • www.sloanvalve.com