

Installation Instructions

Thermostatic Mixing Valve (TMV 130)

Model S59-2130

Inlet Connections: 1-1/4" NPT

Outlet Connections: 1-1/2" NPT

Temperature Range: 85–135°F

Maximum Pressure: 125 PSIG

Inlet Temperature, Hot: 120°–200°F

Inlet Temperature, Cold: 33°–80°F

**Minimum Temperature Differential
(from valve set point): 20°F**

ASSE 1017, CSA & UPC Certified



Table of Contents

Pre-Installation Information	2
Installation Instructions	3
Recirculation Instructions	4
Maintenance	5-6
Troubleshooting	6-7
Parts Breakdown and Service Kits	8

Pre-Installation Information

Overview

The Model TMV 130 Thermostatic Mixing Valve consists of a liquid-filled thermal motor and a piston control mechanism with positive shut-off of hot when there is a loss of cold water supply or thermostat failure. The valve body and cap is constructed of bronze with replaceable corrosion-resistant components, including a stainless steel piston and liner. The valve comes equipped with integral check stops that have removable strainers. The valve may be mounted in any position.

The maximum inlet temperature of the Model TMV 130 Thermostatic Mixing Valve is 200°F (93°C), and the maximum operating pressure is 125 PSI (860 kPA).

Supplies recommended for installation:

- lockable shut-off on the outlet if tempered water is supplied to one or more remote showers
- lockable shut-off on the inlets/supplies
- (6) 3/8" wall anchors and fasteners for surface-mounted cabinet
- (4) 1/4" fasteners (and wall anchors, if necessary) for recess-mounted cabinet
- unions on all connections to facilitate removal of valve

Tools required for temperature adjustment:

- 5/32" Allen key

Product warranties may be found under "Product Information" on our web site at www.bradleycorp.com.

Installation Instructions for Valve

NOTE: Flush the supply lines before beginning installation.

NOTE: When the check valves are in the OPEN (operating) position, the cover screw for the stop/check stem will be flush with the valve cap (see Figure 1).

1. Connect the hot and cold valve supply inlets to the appropriate hot and cold supply piping.
2. Connect the mixed valve supply outlet from the valve to the tempered supply piping.
3. **OPTIONAL THERMOMETER:** Screw the thermometer into the hole in the valve body (see Figure 2). The thermometer provides a readout of the outlet water temperature.
4. Pressurize the thermostatic mixing valve and check for pipe leaks.
5. Slowly open the outlet valve to fill the piping system.
6. Check the temperature when approximately 20 GPM water flow is reached (equivalent to eight standard showers) and adjust if necessary (the range of the valve is 85°F–135°F (29°C–57°C). To adjust the temperature, follow the procedure below:
 - remove the slotted cover screw to expose the set screw
 - using a 5/32" hex-head Allen key, turn the set screw **counterclockwise** to **increase** the temperature or **clockwise** to **decrease** the temperature.
7. Shut the hot water inlet off by closing either the hot water check valve or inlet valve. While the hot water supply is turned off, check to make sure the cold water is reduced to less than 2 GPM. If the cold water is reduced properly, reopen the hot water supply.
8. Shut the cold water inlet off by closing either the cold water check valve or inlet valve. While the cold water supply is off, check to make sure that the hot water flow has shut down.

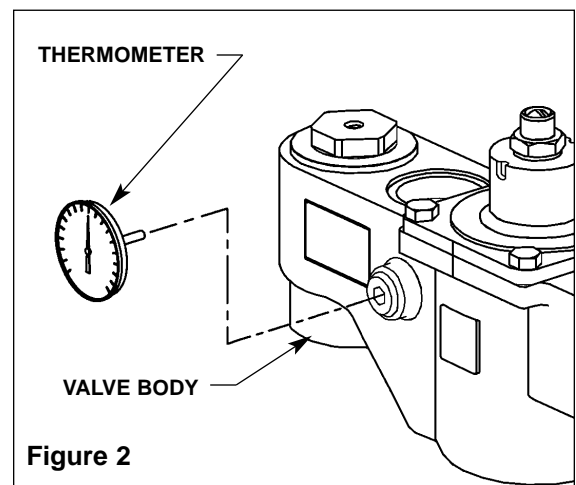
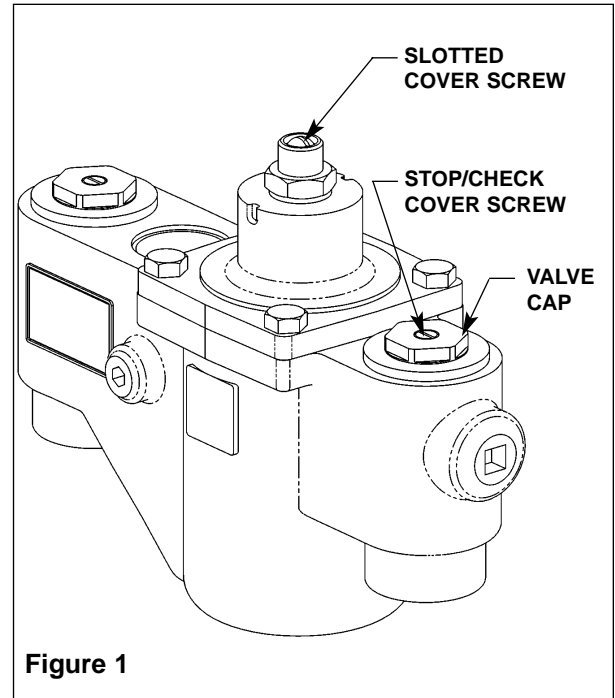

Recirculation Diagram

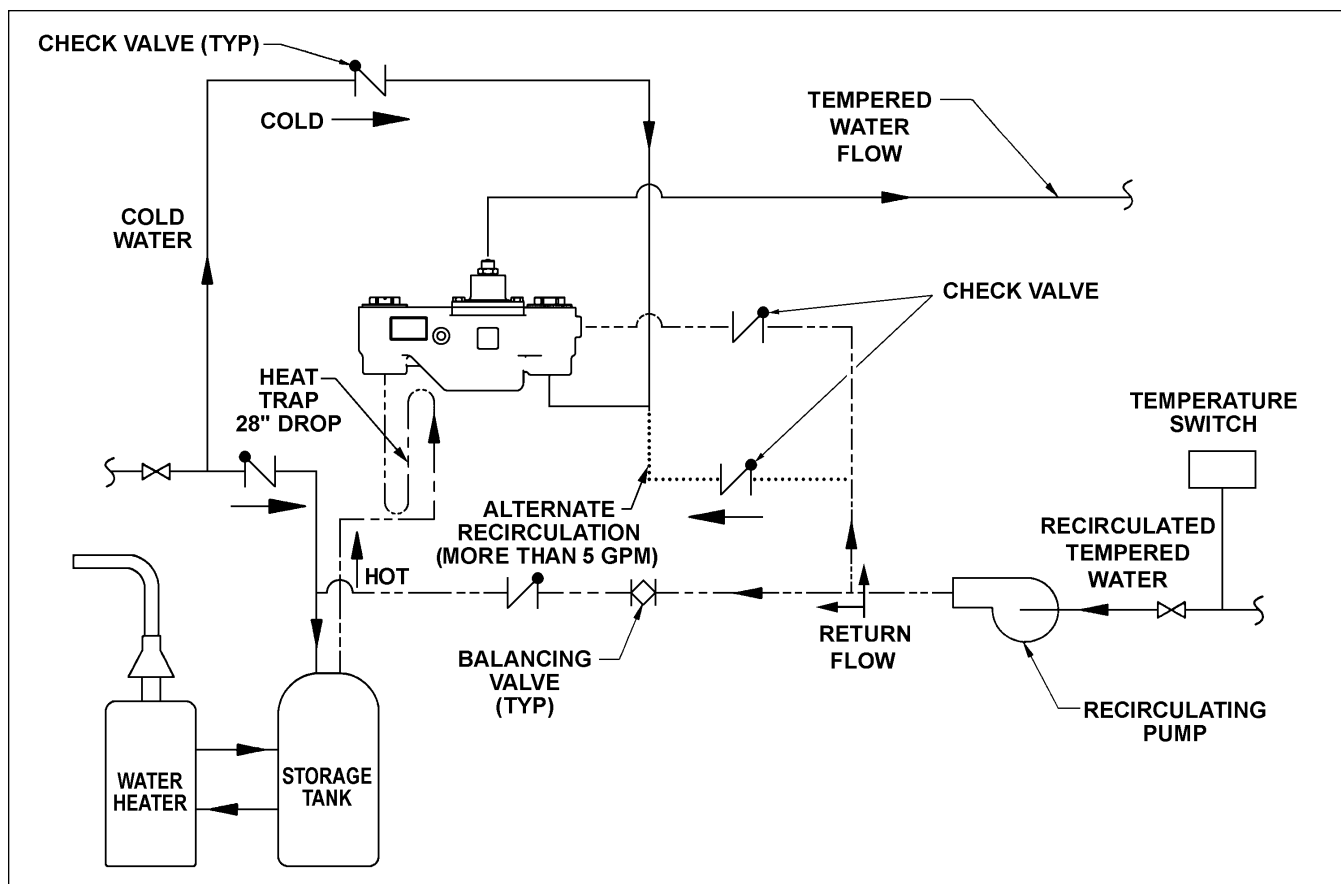

Recirculation Instructions

NOTE: Recirculating the water in the system provides constant regulation of the water temperature. Flush the supply lines thoroughly after completing installation. Close off all fixtures and label them as not in use during the recirculating process.

1. Turn off the recirculating pump and turn on the water supply (a water flow rate of 20 GPM is required).
2. Let the water run through the system until a consistent temperature is obtained. If you do not obtain the required temperature, refer to procedure #6 on page 3 for temperature readjustment.
3. As soon as the water reaches the proper temperature, turn on the recirculating pump (make certain the proper system temperature has been achieved before proceeding).
4. Check the water temperature at the return pump. If the temperature exceeds the appropriate level by 2°F, adjust the temperature high-limit switch (this will turn off the pump). Wait until the return water temperature is 5°F below the appropriate level and adjust the low limit switch (this will turn the pump back on).
5. Turn the balancing valve until it is completely open.
6. Turn off all fixtures and make sure there is no water running through the system (the cold inlet pipe should feel warm to the touch).
7. Let the system run for thirty minutes or longer without water. If, after thirty minutes, the water temperature increases, you may readjust the temperature by slowly closing the balancing valve until the appropriate temperature is reached.

Thermostatic Mixing Valve Maintenance

For maximum efficiency, your thermostatic mixing valve requires a minimum amount of maintenance. Follow the procedures outlined below to achieve highest performance.



WARNING: To prevent injuries, use proper protective equipment for eyes and skin when using a propane torch.

Check the piston for smooth movement

To check the valve's piston for free and smooth movement, follow the procedures outlined below:

1. Remove the valve's top cap and pull out the thermostat and then the push rod (see Figure 3). You may use a needlenose pliers to remove the thermostat from the valve body if desired.
2. Insert a 5/16" dia. rod into the valve and into the piston overheating chamber. Mark the length of the rod inside the valve (see Figure 4).

3. Push the rod until the piston stops and mark the new length of the dowel (the new length should be approximately 9/16" longer than the original length) (see Figure 4). If the length of the dowel is not as it should be, the piston is not moving freely and needs to be cleaned along with the piston liner. Clean the piston and liner following the method outlined below:

- remove the control section assembly from the valve body
- remove the top cap and thermostat
- unthread the liner from the cap (it is glued together; the O-rings must be removed and a propane torch may be required to melt the glue and loosen the liner)
- any cleaner suitable for brass and stainless steel may be used (if cleaning with suitable cleaner is not sufficient to remove debris, a 400-grit sandpaper may be used to polish and hone the piston and liner).

4. If the piston moves freely, push the mechanism up and down several times to make sure the piston moves smoothly and consistently. If movement of the piston is not consistent, recheck the piston and liner for dirt and debris as described in procedure #3.

- if the piston parts need to be replaced, contact your Bradley representative and ask for Piston/Liner Kit (part number S65-214).

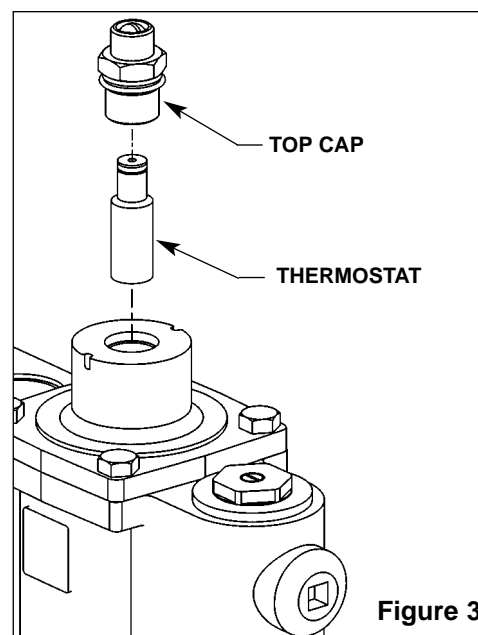

Figure 3

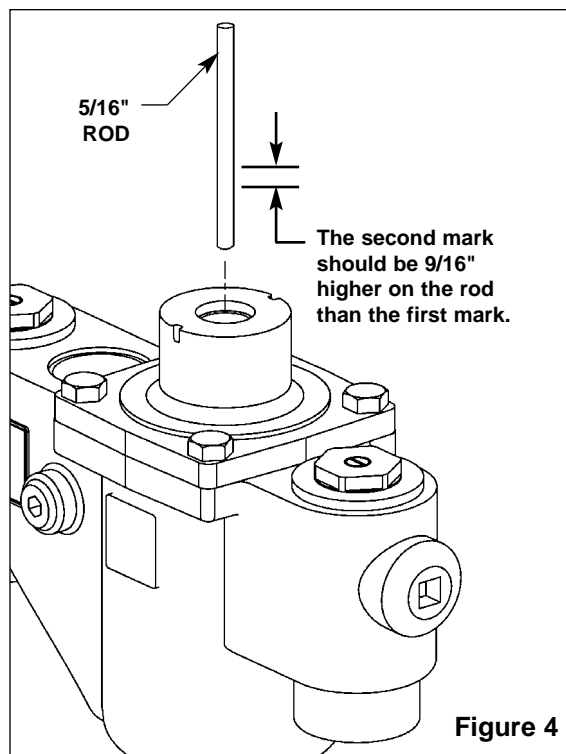

Figure 4

Thermostatic Mixing Valve Maintenance *continued* . . .

Check the thermostat for proper operation

To check the valve's thermostat for proper operation, follow the procedures outlined below.

1. Remove the top cap and pull out the push rod and thermostat (see Figure 3 on page 5).
2. Insert a 5/16" dia. rod into the thermostat bellows. Mark the length of the rod inside the bellows (see Figure 5).
3. Use a marking pen to mark the thermostat bellows length (at room temperature, with 10 lb. of force, the bellows length should be approximately 1-1/8" to 1-5/16") (see Figure 5).
4. If the thermostat bellows length is not in the proper range, the thermostat must be replaced (it cannot be repaired). Contact your Bradley representative and ask for Thermostat Kit (part number S65-191).

Adjust the temperature

To adjust the valve's temperature to other than the factory preset, follow the procedures outlined below.

1. Turn on the water and let it run until at least 20 GPM is flowing through the valve.
2. Remove the slotted cover screw to expose the set screw.
3. Using a 5/32" hex-head Allen key, turn the set screw **counterclockwise** to **increase** the temperature or **clockwise** to **decrease** the temperature.
4. When the adjustment is complete, replace the cover screw and turn off the water.

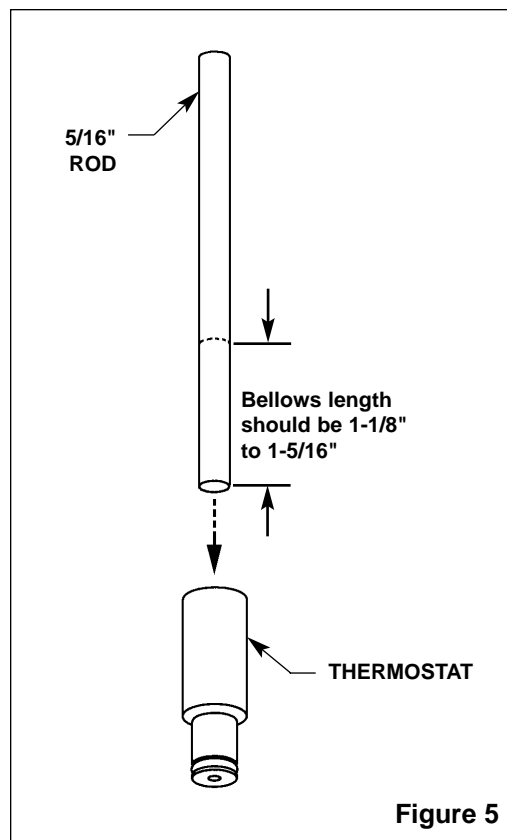

Figure 5

Thermostatic Mixing Valve Troubleshooting

NOTE: Before attempting to troubleshoot the valve or disassemble the components, check for the following conditions:

- *make sure that the check valves are fully open (the slotted stem must be flush with the stop/check cap) (see Figure 1 on page 3) and that all inlet and outlet shut-off valves are open*
- *make sure that the hot and cold inlet pipes are connected properly, and that there are no cross-connections or leaking stop/check valves*
- *check the hot water heater output to make sure that it is at least 15° F above the set temperature.*

Be sure to close the appropriate shut-off valves prior to disassembly of the valve and reopen the valves after inspection and repair is complete.

Problem: No water flow

Cause: The thermostat has failed and subsequently, the safety shut-off has engaged.

Solution: See "Check the thermostat for proper operation" above and follow the step-by-step procedure.

Thermostatic Mixing Valve Troubleshooting *continued . . .*

Problem: Limited water flow

Cause: The stop and check sections of the valve do not move freely.

Solution: Dirt and debris have collected on the check screen or seat, limiting the movement of the stop and checks. Remove the stop and checks, clean the screen and seat and reassemble the valve (see Figure 6). Do not remove the seat. The components may be scraped with a screwdriver to remove debris. A pair of tweezers works well for pulling debris out from the seat. If the stop and checks need to be replaced, contact your Bradley representative and ask for Check/Stop Kit (part number S65-212).

Problem: Improper water temperature

Cause: Valve temperature is not properly set.

Solution: See "Adjusting the temperature" on page 6 and follow the step-by-step procedure.

Problem: External leaks in the system

Cause: Either the NPT joints or the O-rings have been damaged.

Solution: Replace the O-rings where necessary. For replacement of O-rings, contact your Bradley representative and ask for O-Ring/Seal Kit (part number S65-213).

Problem: Temperature fluctuation

Cause: Thermostat is slowly failing.

Solution: See "Check the thermostat for proper operation" on page 6 and follow the step-by-step procedure.

Cause: Recirculation is not balanced.

Solution: See "Recirculation instructions" on page 6 and follow the step-by-step procedure.

Cause: Inlet supply line to the mixing valve is being shared by other pieces of equipment that are used only periodically, such as laundry appliances or washdown stations. It may reduce the inlet pressure to the mixing valve to less than 10 PSI. The supply line size may not be large enough to supply both the valve and the other appliances.

Solution: Enlarge the supply line size, reconfigure the supply line or regulate the supply usage.

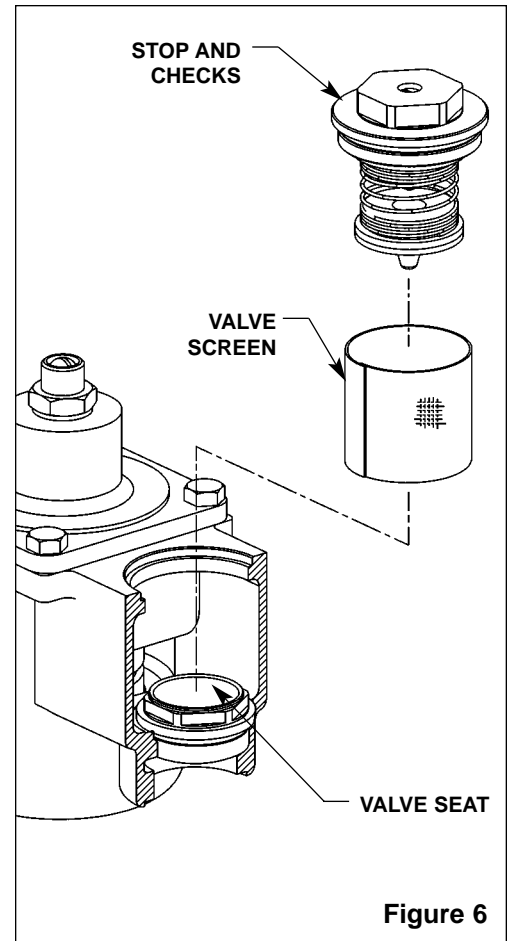
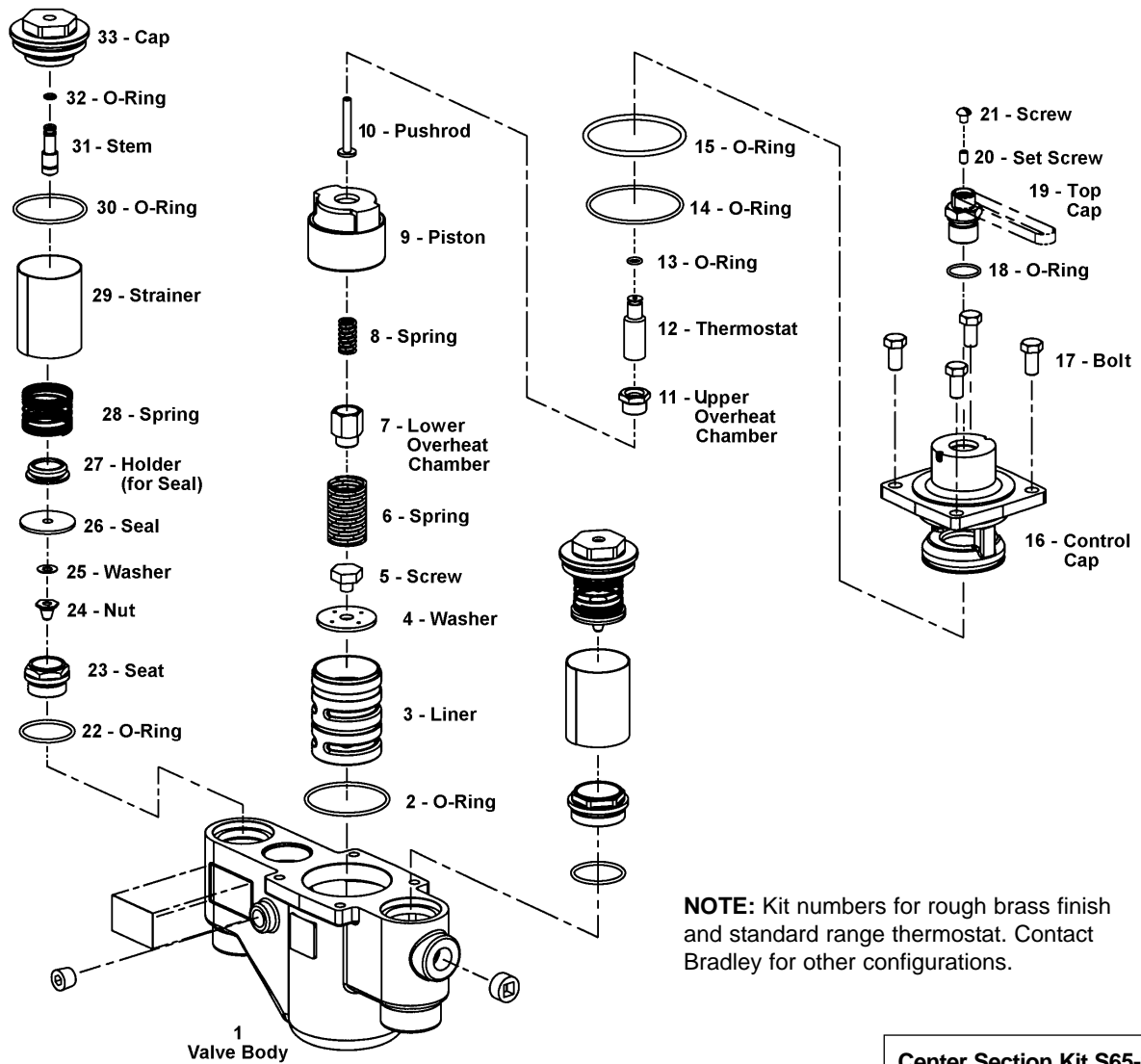

Figure 6

Model S59-2130 Parts Breakdown and Service Kits



NOTE: Kit numbers for rough brass finish and standard range thermostat. Contact Bradley for other configurations.

Thermostat Kit S65-191		
Item	Qty.	Description
12	1	Thermostat
13	1	O-Ring
18	1	O-Ring

Washer/Seal Kit S65-317		
Item	Qty.	Description
4	1	Washer
25	2	Washer
26	2	Seal

Piston & Liner Kit S65-214		
Item	Qty.	Description
2	1	O-Ring
3	1	Liner
4	1	Washer
5	1	Screw
6	1	Spring
7	1	Lower Chamber
8	1	Spring
9	1	Piston
11	1	Upper Chamber

O-Ring Kit S65-213		
Item	Qty.	Description
2	1	O-Ring
13	1	O-Ring
14	1	O-Ring
15	1	O-Ring
18	1	O-Ring
22	2	O-Ring
30	2	O-Ring
32	2	O-Ring

Check/Stop Kit S65-212		
Item	Qty.	Description
22	2	O-Ring
23	2	Seat
24	2	Nut
25	2	Washer
26	2	Seal
27	2	Holder (for Seal)
28	2	Spring
29	2	Strainer
30	2	O-Ring
31	2	Stem
32	2	O-Ring
33	2	Cap

Center Section Kit S65-297		
Item	Qty.	Description
2	1	O-Ring
3	1	Liner
4	1	Washer
5	1	Screw
6	1	Spring
7	1	Lower Overheat Chamber
8	1	Spring
9	1	Piston
10	1	Pushrod
11	1	Upper Overheat Chamber
12	1	Thermostat
13	1	O-Ring
14	1	O-Ring
15	1	O-Ring
16	1	Control Cap
17	4	Bolt
18	1	O-Ring
19	1	Top Cap
20	1	Set Screw
21	1	Screw