



**AQUARIUS**

*Kelvinator*

White-Westinghouse®

# ILLUSTRATED PARTS BREAKDOWN

## MODULAR ON-A-WALL WATER COOLER MODELS:

**MDFS8, MDFS8-P, MDFS8-PE SERIES**

**MLF8M, MLF8MPE, MLF8MPM SERIES**

## DRINKING FOUNTAIN MODELS:

**MDFS, MDFS-P, MDFS-PE SERIES**

**MLFM, MLFMPE, MLFMPM SERIES**

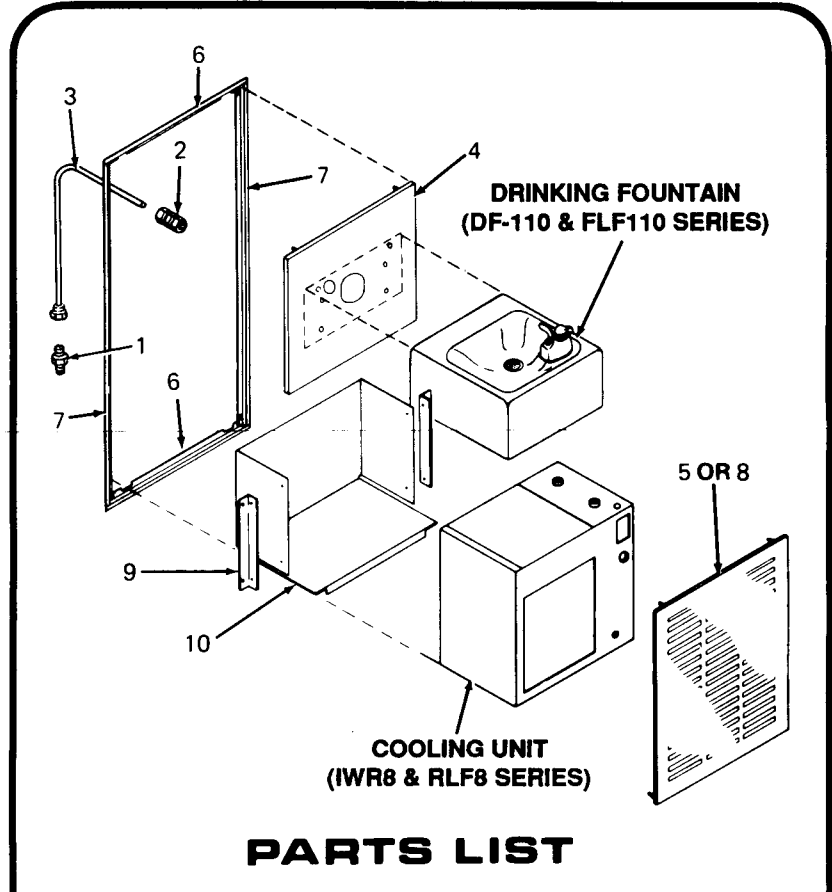
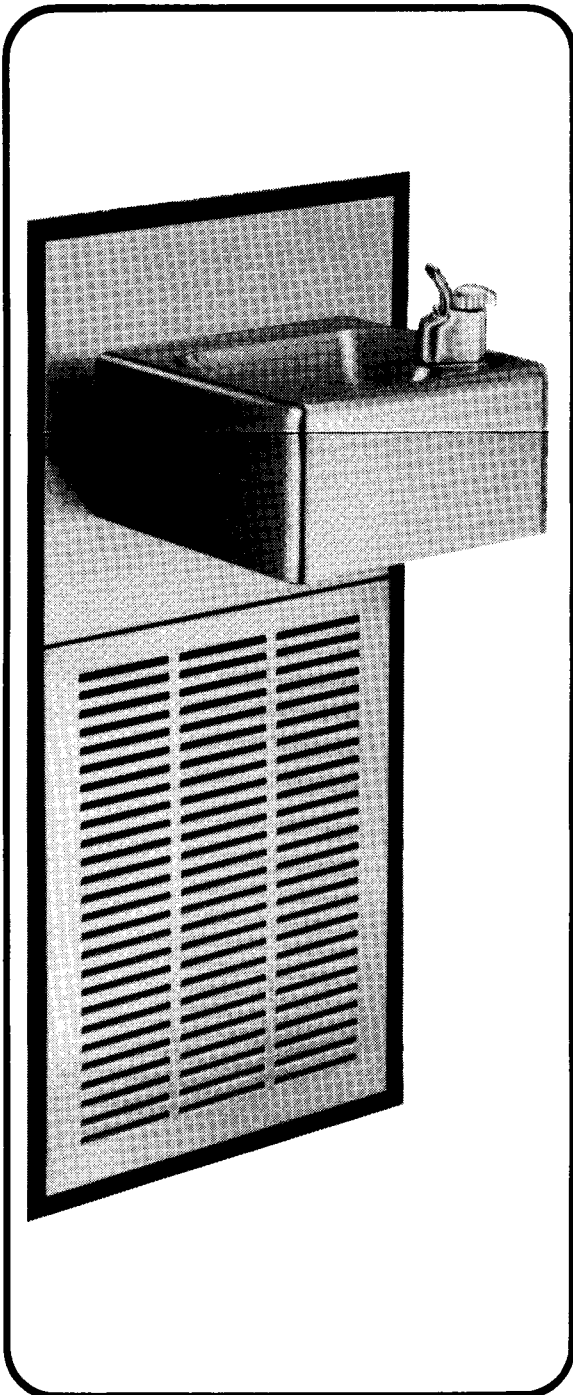

### PARTS LIST

ITEM NO.	DESCRIPTION	
1	Connector Male Flare Fitting, **3/8 OD x 3/8 NPT .....	021558
2	Union Compression Fitting, **3/8 OD (MDF Series) .....	025813
	Coupling, 3/8 x 3/8 (MLF Series) .....	029170-001
3	Unit to Bubbler Tube Assembly (MDF Series) .....	025815
	Unit to Bubbler Tube Assembly (MLF Series) .....	029264-001
4	Upper Panel Assembly (For DF-110 & FLF110) .....	025606-001
5	Grille Assembly .....	025605-001
6	Top and Bottom Trim Strip .....	025321-001
7	Side Trim Strip .....	025320-002
8	Lower Panel Assembly (For Fountain Only) .....	025604-001
	Cooling Unit, IWR8 & RLF8 .....	Form No. 2165 & 2271-1
	Drinking Fountain, DF-110 & FLF110 .....	Form No. 6001, 6023 & 6033

### ROUGHING-IN & DIMENSIONAL DRAWING

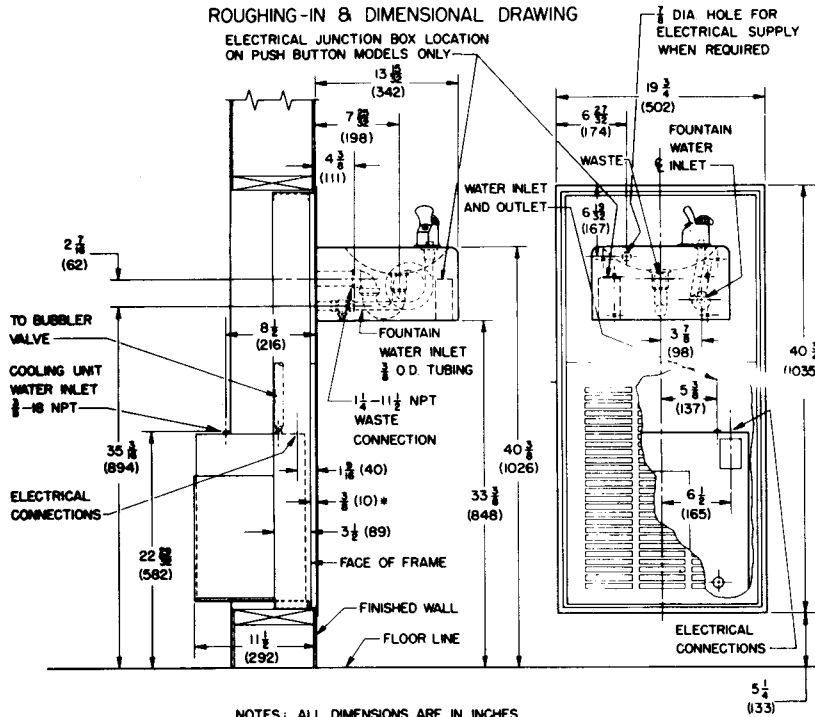

NOTES: ALL DIMENSIONS ARE IN INCHES.  
 DIMENSIONS IN PARENTHESES ( ) ARE IN MILLIMETERS.  
 STOP VALVE NOT PROVIDED WITH UNIT.

### WALL OPENING & ASSEMBLY

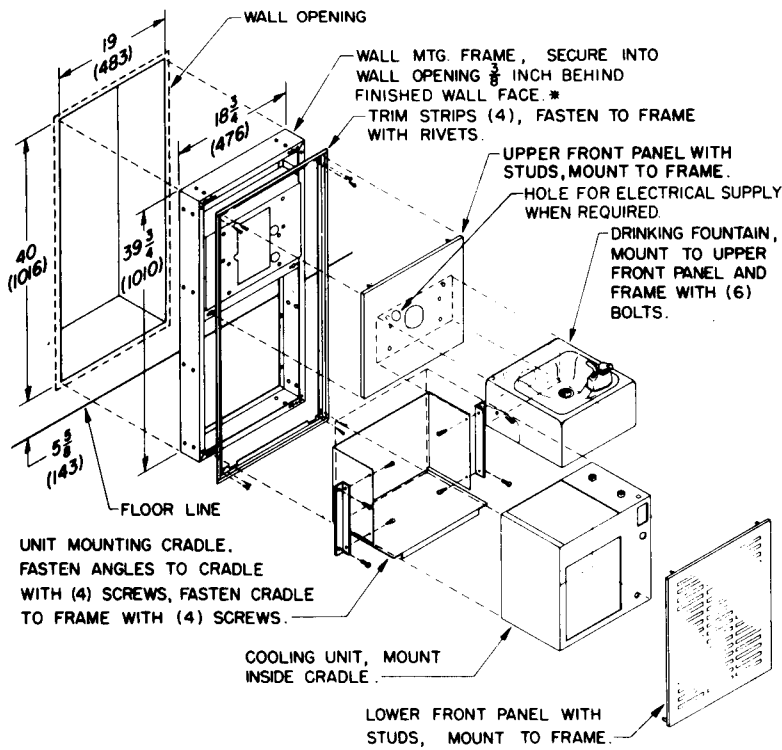

OASIS® & AQUARIUS® are registered trademarks of EBCO Manufacturing Company  
 The trademarks Kelvinator® and White-Westinghouse® are used under license from White Consolidated Industries, Inc.

**EBCO®** MANUFACTURING COMPANY

265 N. Hamilton Rd. • P.O. Box 13150 • Columbus, OH 43213-0150 • 614/861-1350 • Fax: 614/861-5017

Printed in U.S.A.  
 Copyright 1993 EBCO Manufacturing Co.