



AMERICAN SPECIALTIES, INC.

441 Saw Mill River Road, Yonkers, NY 10701 (914) 476-9000

MODEL No: 0864

ISSUED: 1-87

REVISED: 10-04

SURFACE MOUNTED DUAL SANITARY NAPKIN AND TAMPON DISPENSER (PAGE 1/2)

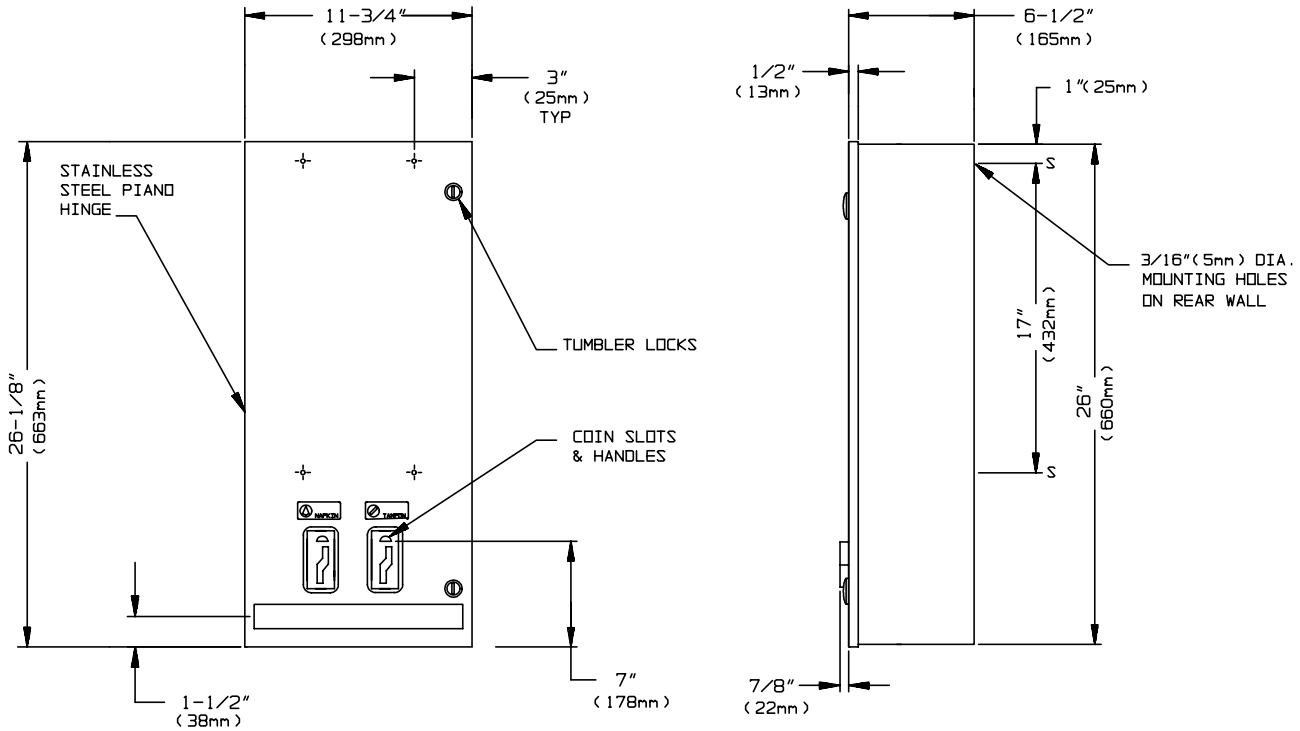

SPECIFICATION

Surface Mounted Dual Sanitary Napkin & Tampon Dispenser shall hold 30 napkins and 27 tampons of specified sizes and shall have door fabricated of alloy 18-8 stainless steel, type 304, 18gauge. All exposed surfaces shall be N° 4 satin finish and be protected during shipment with a PVC film easily removable after installation. Cabinet shall be fabricated of 22 gauge same grade stainless steel and shall have door attached with a full length 3/16" dia. (5mm) stainless steel multi-staked piano hinge and shall be held closed with two (2) tumbler locks keyed alike to other ASI washroom equipment. Internal coin-box shall be keyed differently than door locks. Dispensing mechanisms shall be fastener mounted internally to provide ability to change mechanisms for coinage denomination. Structural assembly of body and door components shall be of welded construction and have no exposed fasteners or welded seams. Weights for each feed track shall be supplied. Factory installed coin operation denomination shall be _____. (please fill in 25¢ or 50¢; or FREE and add denomination as suffix to model N° (i.e. 0864-25)).

Surface Mounted Dual Sanitary Napkin & Tampon Dispenser shall be Model N° 0864-xx of American Specialties, Inc., 441 Saw Mill River Road, Yonkers, NY 10701-4913

INSTALLATION

Unit is surface mounted using four (4) N° 10 self-tapping screws (by others). For maximum usability and compliance with ADA Accessibility Guidelines, unit should be installed so that coin slot is between 54" (1372mm) maximum above finished floor (AFF) and 38" (965mm) minimum AFF. Installer must provide adequate wall anchoring for screw mounting.

Accessory Specialties

AMERICAN DISPENSER

Desert Ray Products

WATROUS .INC.



AMERICAN SPECIALTIES, INC.

441 Saw Mill River Road, Yonkers, NY 10701 (914) 476-9000

MODEL No: 0864

ISSUED: 1-87

REVISED: 10-04

SURFACE MOUNTED DUAL SANITARY NAPKIN AND TAMPON DISPENSER (PAGE 2/2)

OPERATION

Deposit of specified coin allows operation of dispenser. Napkin and tampon dispensers operate independently. Selected product drops into vending opening after operator actuation. Unit vend product supply is replenished on cycle determined by maintenance needs by opening door and manually reloading product into dispenser supply tracks. Track weights **MUST BE USED** to provide positive feed.

NAPKINS, SINGLES, CARDBOARD-BOXED, SEMIGLOSS FINISH; CAPACITY: 30, BOX SIZE: 4-1/4" x 3" x 1-1/8" (108mm x 76mm x 29mm)

Stayfree	No. 4
Guards	No's. 247, or 147
Kotex	No's. 704, 707, 07010, 07040, 07045, 07300, 07320
Pure-Nat	No. M-4
Modess	No. 4

TAMPONS, CYLINDER, CARDBOARD, SEMIGLOSS, CRIMPED ENDS; CAPACITY: 27, TUBE SIZE: 3/4" dia. x 5-1/4" (19mm x 134mm)

Tampax	
Modess Tampons	