

CHICAGO<sup>®</sup>  
FAUCETS

2100 SOUTH CLEARWATER DRIVE  
DES PLAINES, ILLINOIS 60018-5999

FITTING NO.

942

SUBMITTED MODEL NO.

JOB NAME

ITEM NO.

SUBMITTED AS SHOWN

SUBMITTED AS NOTED

SEE ATTACHED FOR  
SUBMITTED MODIFICATION

IS ASSUMED FOR USE OF SUPERCEDED OR VOIDED DATA. (0192-1)

ROUGHING IN DIMENSIONS MAY VARY AND ARE SUBJECT TO CHANGE. NO RESPONSIBILITY

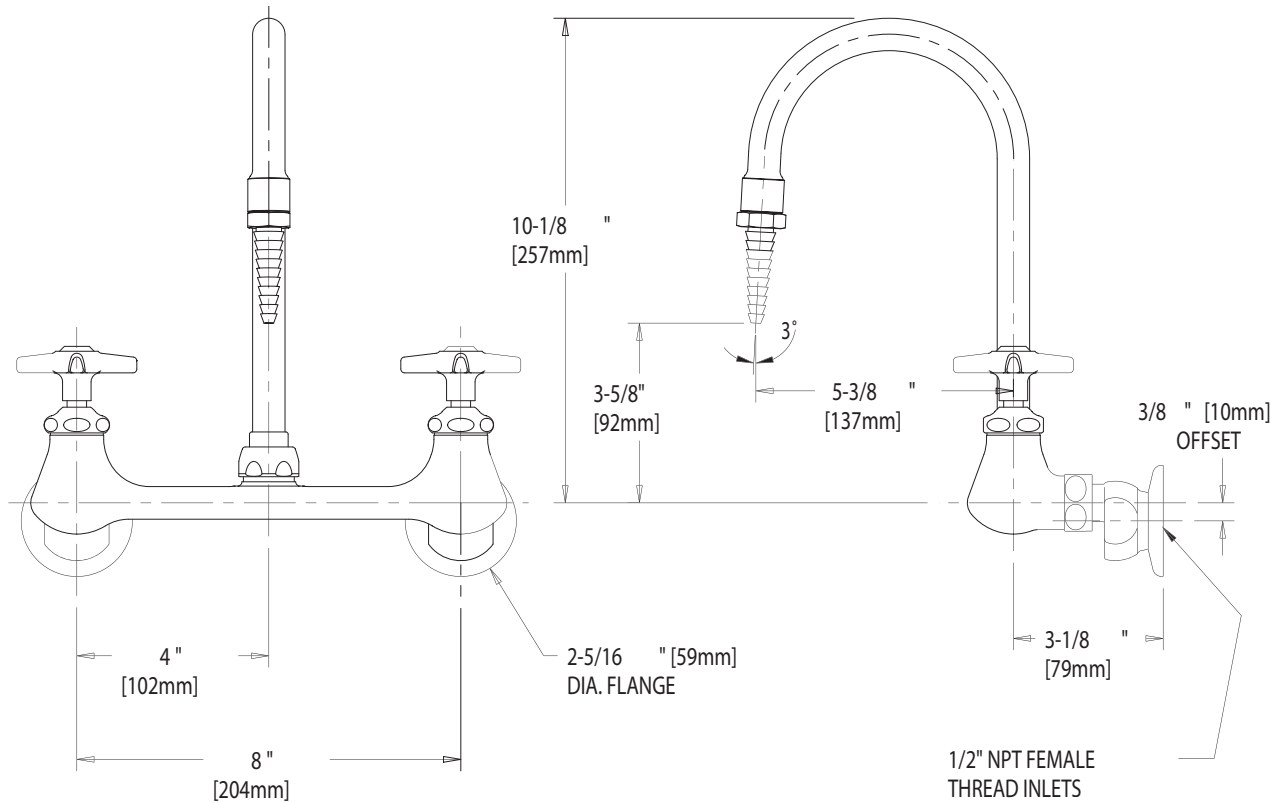

DIMENSIONS IN INCHES AND [MILLIMETERS].

TECHNICAL DATA

- WALL MOUNTED LABORATORY FITTING
- GN2B RIGID/SWING GOOSENECK SPOUT
- 204 INDEXED 4-ARM HANDLES
- SLO-COMPRESSION UNITS
- POLISHED CHROME FINISH OR AS SPECIFIED

- 'G' ADJUSTABLE SUPPLY ARMS
- E7 LAB NOZZLE OUTLET
- ANSI A112.18.1 COMPLIANT
- CSA B125 COMPLIANT

DATE: 05-22-97

BY: MGM

CHK'D:

APP'D:

REV: 04-24-99

942