

Eye/Face Wash Fixture w/ Hinged Dust Cover and Wall Bracket

Model S19-220DCR

- Complies with American National Standard Z358.1-2004
- Galvanized Steel Protected with BRADTECT™ Safety Yellow Coating
- Universal Identification Sign and Inspection Tag Included
- Full, One-Year Warranty

Specifications

Unit design saves space and fits easily into any work environment. Eyewash operates quickly by a large, highly visible push handle. Safe, steady water flow under varying water supply conditions from 30-90 PSI is assured by integral flow control in the sprayhead assembly.

UPC and cUPC Approved:

The Emergency Fixtures are certified to comply with the requirements of the Uniform Plumbing Code and the National Plumbing Code of Canada by the International Association of Plumbing and Mechanical Officials (IAPMO).

Construction

Eyewash bowl, hinged dust cover and push handle are stainless steel. Galvanized steel piping and wall mounting bracket are additionally protected with BRADTECT™ safety yellow coating. Chrome plated tailpiece provided.

Standard Equipment

Eyewash Bowl

10" (254mm) diameter stainless steel.

Standard Sprayhead Assembly

Chrome-plated brass sprayhead assembly with twin, soft flow, eyewash heads and protective sprayhead covers. The integral flow control assures safe, steady flow under varying water supply conditions from 30-90 PSI.

Face Spray Ring

Chrome-plated circular spray ring provides supplemental face spray. Flow control assures adequate flow from eyewash nozzles and face spray ring from 30-90 PSI.

Valve

Chrome-plated brass 1/2" IPS stay-open ball valve. Hand operated by a large, highly visible stainless steel push handle.

Hinged Dust Cover

Stainless steel dust cover keeps contaminants, dust and debris from eye washing area.

Pipe and Fittings

1/2" galvanized steel protected with BRADTECT™ safety yellow coating.

Wall Bracket

Heavy-gauge sand cast aluminum protected with BRADTECT™ safety yellow coating. Three clearance holes for wall mounting bracket; bolts by others.

Waste

Dome-type strainer, 1-1/4" drain fitting and tailpiece furnished.

Water Supply

1/2" IPS.

Document No. 4300

This information is subject to change without formal notice.
© 2006 Bradley Corporation
10-11-2006 (2 Pages Total)



Recommended Option:

Navigator S19-2000 EFX8
Emergency Thermostatic Mixing Valve

NAVIGATOR

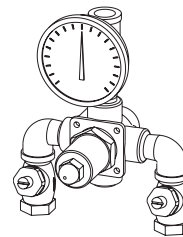

Satisfies ANSI Z358.1-2004
tepid water requirements.

Bradley 

P.O. Box 309, Menomonee Falls, WI 53052-0309
Phone 1-800-BRADLEY FAX 262-251-5817
Web Site: <http://www.bradleycorp.com>



SEI CERTIFIED
MODEL
Z358.1-2004

Eye/Face Wash Fixture w/ Hinged Dust Cover and Wall Bracket

Model S19-220DCR

MODEL	
Model No.	Description
<input type="checkbox"/> S19-220DCR	Eye/Face Wash Fixture w/ Hinged Dust Cover and Wall Bracket
<input type="checkbox"/> S19-2000	Navigator EFX8 – Emergency Thermostatic Mixing Valve

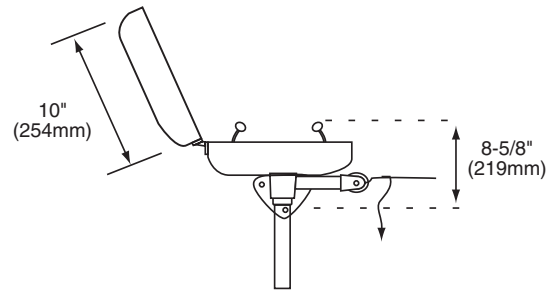
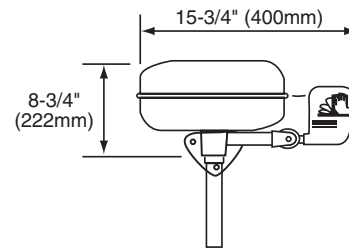
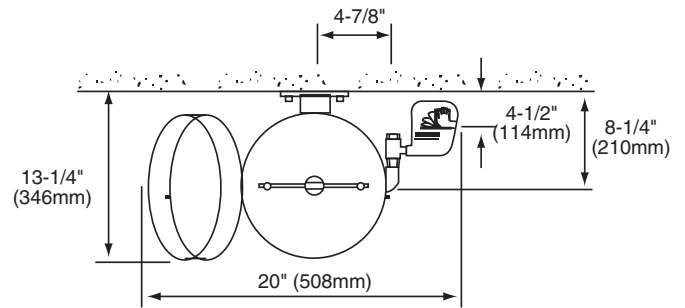

Document No. 4300

This information is subject to change without formal notice.
© 2006 Bradley Corporation
10-11-2006 (2 Pages Total)

EF4300.2



P.O. Box 309, Menomonee Falls, WI 53052-0309
Phone 1-800-BRADLEY FAX 262-251-5817
Web Site: <http://www.bradleycorp.com>