

CHICAGO FAUCETS



2100 SOUTH CLEARWATER DRIVE
DES PLAINES, ILLINOIS 60018-5999

Last As Long As The Building

FITTING NO.

962-VOG

SUBMITTED MODEL NO.

JOB NAME

ITEM NO.

SUBMITTED AS SHOWN

SUBMITTED AS NOTED

SEE ATTACHED FOR
SUBMITTED MODIFICATION

IS ASSUMED FOR USE OF SUPERCEDED OR VOIDED DATA. (0192-1)

ROUGHING IN DIMENSIONS MAY VARY AND ARE SUBJECT TO CHANGE. NO RESPONSIBILITY

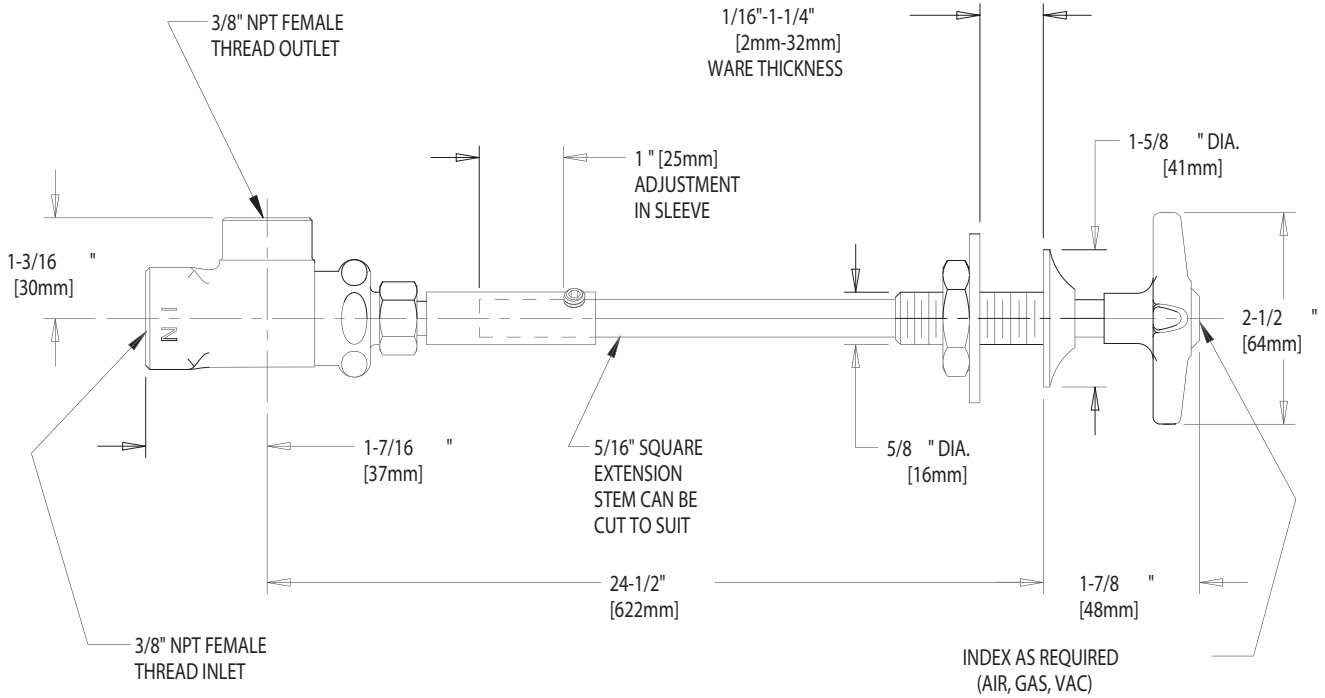

DIMENSIONS IN INCHES AND [MILLIMETERS].

TECHNICAL DATA

- REMOTE CONTROL GAS LABORATORY FITTING
- ANGLE STOP VALVE
- 204 INDEXED 4-ARM HANDLE
- NEEDLE VALVE CARTRIDGE
- POLISHED CHROME FINISH OR AS SPECIFIED

- 90° ROD GUIDE FLANGE
- ANSI A112.18.1 COMPLIANT

DATE: 05-28-97

BY: SID

CHK'D:

APP'D:

REV: 03-07-02

962-VOG