

CHICAGO[®] FAUCETS

2100 SOUTH CLEARWATER DRIVE
DES PLAINES, ILLINOIS 60018-5999

FITTING NO.

930-317

SUBMITTED MODEL NO.

JOB NAME

ITEM NO.

SUBMITTED AS SHOWN

SUBMITTED AS NOTED

SEE ATTACHED FOR
SUBMITTED MODIFICATION



ADA COMPLIANT

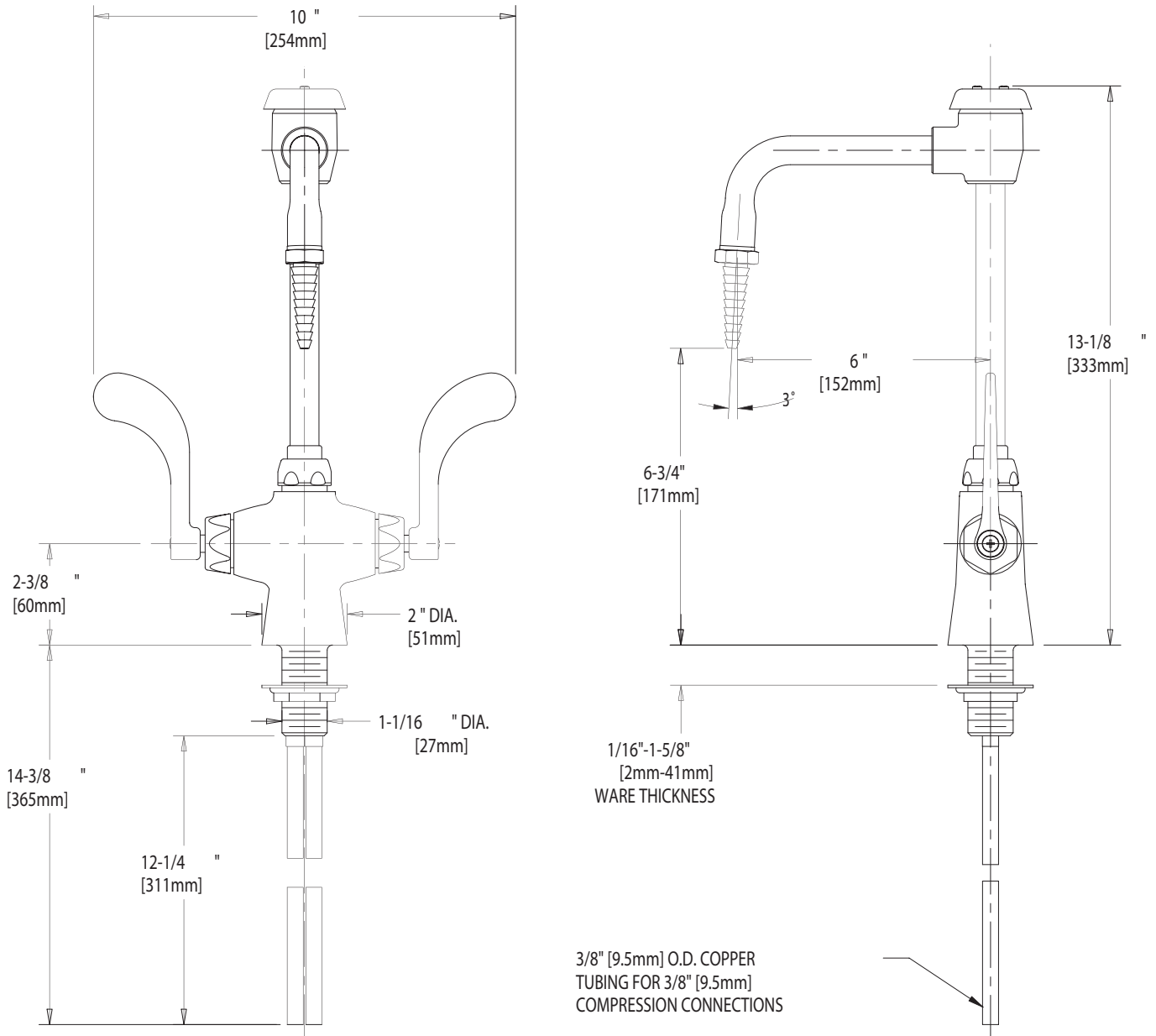

DIMENSIONS IN INCHES AND [MILLIMETERS].

TECHNICAL DATA

- DECK MOUNTED COMBINATION LABORATORY FITTING
- GN2BVB RIGID/SWING VACUUM BREAKER SPOUT
- 317 INDEXED WRISTBLADE HANDLES
- QUATURN UNITS
- FINISH OR AS SPECIFIED

- 3/8" [9.5mm] COPPER SUPPLY TUBES
- E7 LAB NOZZLE OUTLET
- ANS1 A112.18 COMPLIANT
- CSA B125 COMPLIANT

DATE: 11-25-98

BY: MGM

CHK'D:

APP'D:

REV:

930-317

IS ASSUMED FOR USE OF SUPERCEDED OR VOIDED DATA. (0192-1)

ROUGHING IN DIMENSIONS MAY VARY AND ARE SUBJECT TO CHANGE. NO RESPONSIBILITY