

# ELKAY<sup>®</sup> SPECIFICATIONS

## Outdoor Tubular Fountain

### MODEL LK4405FRK

#### GENERAL

Steel Outdoor Freeze-Resistant Wall Mount Fountain with rounded corner design, heavy-duty steel with textured powder-coat finish and E-Coat immersion for year-round beauty with minimum maintenance. The E-Coat immersion process coats the inside and outside for the ultimate in corrosion protection.

#### BUBBLER

Vandal-resistant bubbler is one-piece, heavy-duty construction. Unit has integral hood guard design to prevent contamination from other users, airborne deposits and tampering.

#### FREEZE-RESISTANT VALVE SYSTEM

Freeze-Resistant system features box that installs behind non-freezing wall for housing water connection from the stop to the strainer.

#### BASIN

Contour-formed stainless steel design with rounded edges reduces splatter, ensures proper drainage and prevents standing water.

#### PUSHBUTTON ACTUATION MECHANISM

Self-closing, vandal-resistant pushbutton does not require grasping or twisting.

#### WATER INLET & DRAIN OUTLET

Inlet: 3/8" O.D. Tubing

Outlet: 1-1/4" tube outlet for 1-1/4" slip joint connection

#### ACCESS PANELS

Heavy-gauge steel with vandal-resistant screws. Provides access for easy hook-up of all plumbing connections.

#### SUGGESTED SPECIFICATIONS

Unit shall include powder-coated finish with vandal-resistant pushbutton actuation, vandal-resistant bubbler with integral hood guard, and contour-formed rounded basin to reduce splash and prevent standing water. Shall include Freeze-Resistant valve system. Fountain shall comply with ANSI 117:1 and ADA for visual and motion disabilities. The manufacturer shall certify the unit to meet the requirements of NSF/ANSI 61, and the Safe Drinking Water Act.

Model	Color Option	 C USA	
		ADA Compliant	NSF/ANSI 61 Certified
LK4405FRK*	(Refer to Finish Color Options)	•	•

\* Select color option to complete model number. Example: LK4405FRKEVG

### Freeze-Resistant Wall Mount Fountain



Model LK4405FRK is shown.

Now Available  
in 12 Colors!



**FINISH COLOR OPTIONS** – Choose color option to complete your model number, add as suffix example: LK4405FRKEVG

Matte finish:  Evergreen = EVG

Gloss finish:

- |                                      |                                       |   |
|--------------------------------------|---------------------------------------|---|
| <input type="checkbox"/> Beige = BGE | <input type="checkbox"/> Gray = GRY   | <input type="checkbox"/> Terracotta = TER |
| <input type="checkbox"/> Black = BLK | <input type="checkbox"/> Orange = ORN | <input type="checkbox"/> White = WHT      |
| <input type="checkbox"/> Blue = BLU  | <input type="checkbox"/> Purple = PUR | <input type="checkbox"/> Yellow = YLW     |
| <input type="checkbox"/> Brown = BRN | <input type="checkbox"/> Red = RED    |   |

Each 4405 FR consists of 2 cartons of the following:

- Fountain
- Freeze-Resistant Box - LKFRB1

*This specification describes an Elkay product with design, quality and functional benefits to the user. When making a comparison of other producer's offerings, be certain these features are not overlooked.*

# MODEL LK4405FRK

## Outdoor Tubular Wall Mount

### Freeze-Resistant Fountain

#### MOUNTING INSTRUCTIONS and PLUMBING CONNECTIONS

Refer to diagrams for plumbing rough-in. This fountain is to be mounted on a smooth, flat finished wall surface with adequate support.

**Note:** Wall mounting structure must be capable of supporting a 300 lb. load minimum on fountain. To secure unit, use 3/8" minimum fasteners (not provided). Water service line and waste line are to be assembled as required. Final check for leaks and correct functions of fountain should be made. (For details see the installation instructions.)

The Freeze-Resistant package must be mounted on an interior wall in a heated area. (See details in the installation instructions.)

**Installation requires trap to be installed in wall. A service supply stop must be installed at the fountain inlet line. Trap and service stop not included.**

**Caution – Fountain must be securely bolted to wall.**

**NOTE:** For wall support required locations see installation instructions provided with fountain.

**OPERATING PRESSURES:** Supply water 20 – 105 psi maximum

#### TOP VIEW

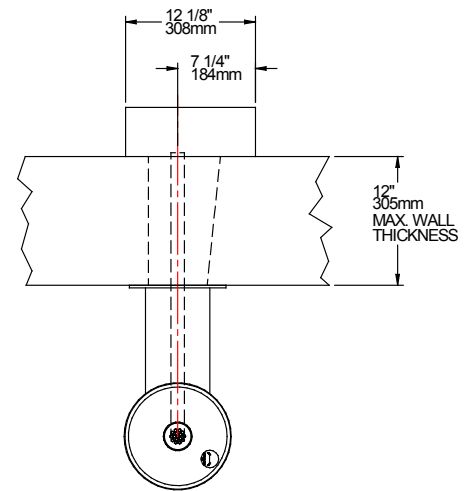

#### MOUNTING BOLT & ACCESS HOLE LOCATION

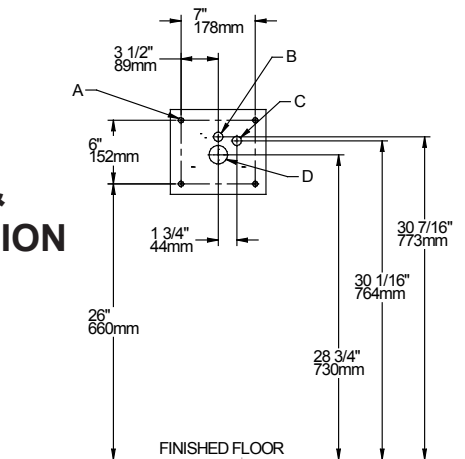

#### FRONT & SIDE VIEWS

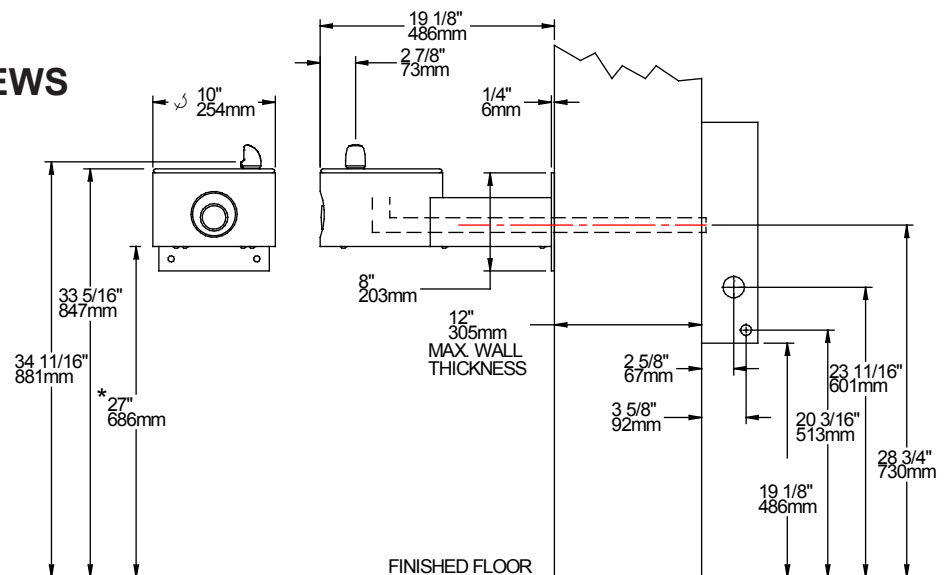

#### LEGEND

- A = MOUNTING SCREW OR BOLT LOCATIONS
- B = 7/8" DIA. (22mm) HOLE FOR WATER SUPPLY TUBE
- C = 7/8" DIA. (22mm) HOLE FOR OPERATING CABLE
- D = 2" DIA. (51mm) HOLE FOR WASTE LINE

\* ADA Requirement