

SENTINEL MARK II®

SM-4421

Anti-Scald Balanced Pressure Shower

SM-4421

Sentinel Mark II concealed anti-scald balanced pressure shower with integral volume control/diverter and integral stops. Chrome plated brass wall plate with decorative etched metal index. Chrome plated brass Reverse handle. Independent center sleeve allows up to 1" of rough-in variation. Adjustable temperature limit stop. Brass body. Pressure balancing and ceramic temperature regulating cartridge with built-in check valves. Can be installed back-to-back. Roughing-in template. Vandal-resistant standard. S-2280-AF Anystream® wall mounted showerhead with flow control device reduces flow to 2.5 gpm/9.46 lpm maximum to meet existing ASME A112.18.1/CSA B125.1 standard. Vandal-resistant standard. Four port valve with 1/2" female copper sweat inlets and shower outlet. 1/2 female NPT tub outlet. Furnished with 1/2" pipe plug. Meets ASSE 1016 & ASME 112.18.1/CSA B125.1.



OPTIONS

SUFFIX	DESCRIPTION
--------	-------------

- | | |
|-----------------------------|-----------------------|
| <input type="checkbox"/> AP | Anchor plate assembly |
| <input type="checkbox"/> BJ | Ball joint |
| <input type="checkbox"/> 2 | S-2252-AF showerhead |
| <input type="checkbox"/> 6 | S-2288-AF showerhead |

Contractor packs available upon request.

This space for Architect/Engineer approval.



Rough-Ins

SM-4421

1" (25mm) DIA
 HOLE FOR SHOWER

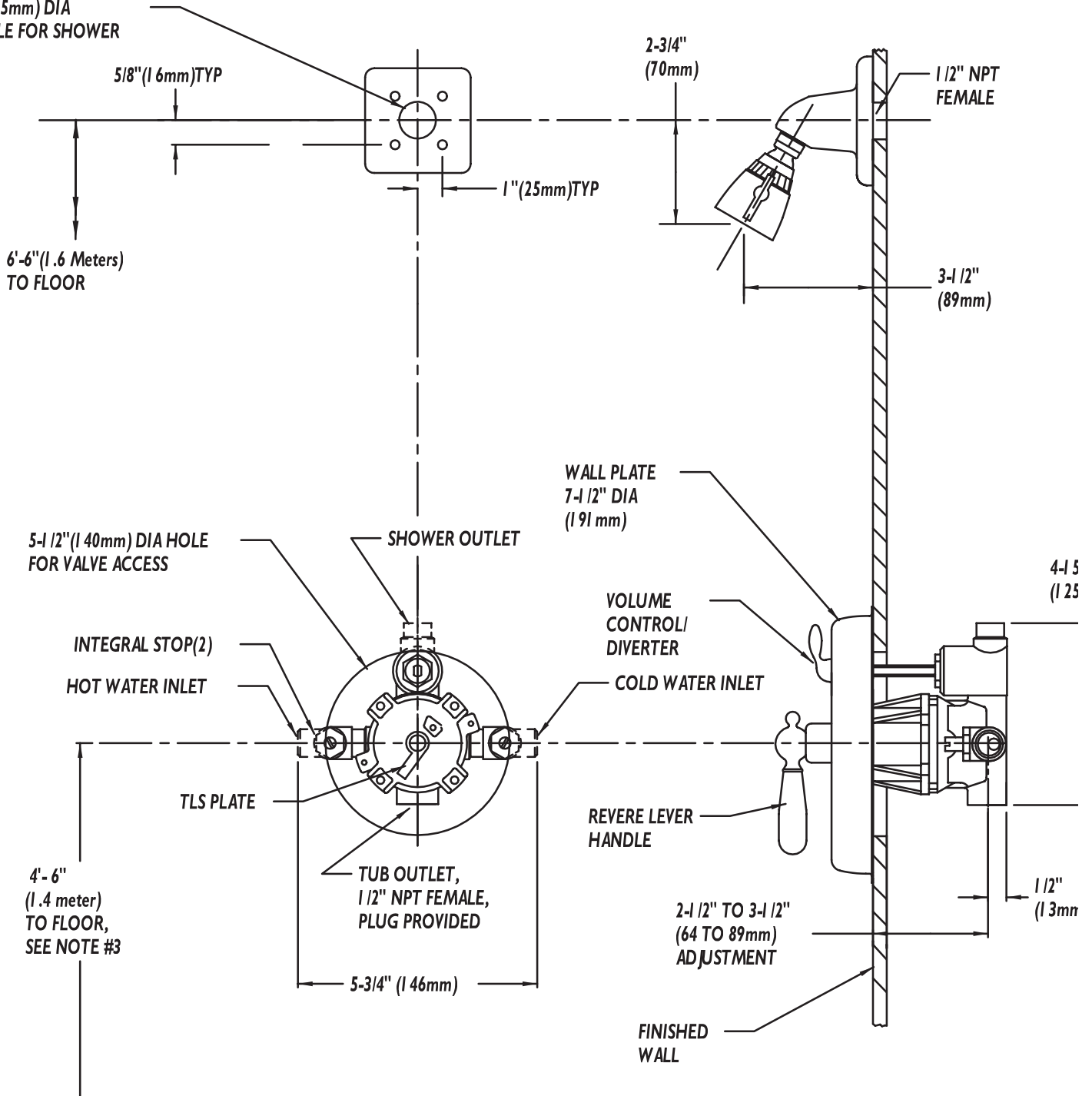

NOTE: All dimensions are in inches (millimeters) unless otherwise specified and are subject to change without notice. Unless otherwise specified all inlets and outlets are 1/2" female copper sweat. For ADA mounting locations consult ADAAG, ANSI A117.1, or state regulations.