



WIDESPREAD METERING

Z867C0-XL

TAG _____



Engineering Specifications: Zurn AquaSpec® Z867C0-XL

Polished chrome-plated 8" [203mm] widespread faucet with an 8" [203mm] centerline gooseneck rigid or swing spout, slow-closing metering cartridges, and vandal resistant color-coded metal handles. Easily adjustable cycle time, preset to 10 seconds at 80 PSI. Unit is furnished with a water-conserving aerator which reduces flow to 25 GPM [.95 L] (complying with ANSI A112.18.1 Standard for flow), mounting hardware, 1/2" NPSM coupling nuts for standard lavatory risers and integral shank filters.

Zurn Lead Compliant* "XL" products are a line of durable, high quality brass faucets and fixtures that are designed and manufactured to comply with state laws and local codes that mandate lead content levels. Zurn "XL" products are manufactured with *not more than 0.25% lead content when used with respect to wetted surfaces of pipes and pipe fittings, plumbing fitting and fixtures: California Health & Safety Code § 116875; Vermont 9 VCA § 2470h.

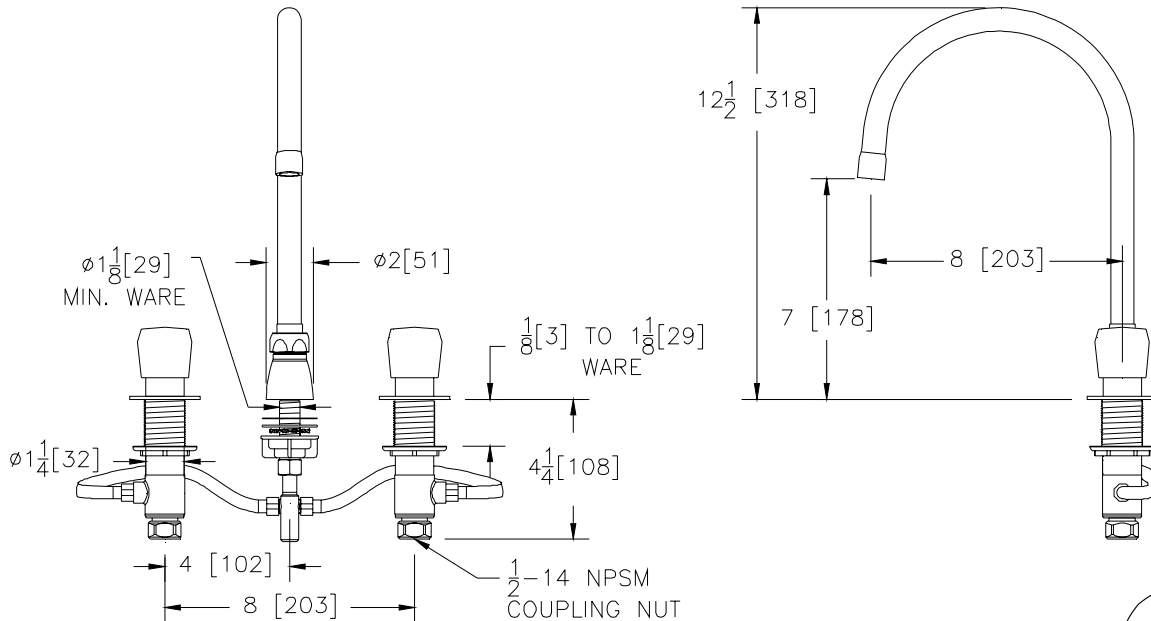

Note: All dimensions are for reference only. Do not use for pre-plumbing



OPTIONAL ACCESSORIES

Suffix	Description
___ -CWO	Cold Water Only
___ -G	1-1/4" [32mm] Grid Strainer Drain
___ -GH	1-1/4" [32mm] Offset Handicap Drain
___ -ICT	Inter-connecting Copper Supply Tubes for 8" In-line Centers
___ -IN	Institutional Handle - Tamper-Proof and Vandal-Resistant
___ -P	1-1/4" [32mm] Pop-up Drain
___ -PT	1-1/4" [32mm] Cast Brass P-Trap with a 7-1/2" [191mm] Long 17-Gauge Wall Bend
___ -RKR	ADA Compliant Rocker Handle
___ -140	140° Restricted Swing Spout
___ -3F	0.5 GPM [1.9 L] Vandal-Resistant Pressure Compensating Female Spray Outlet
___ -16F	1.0 GPM [3.8L] Vandal-Resistant Pressure Compensating Female Spray Outlet

ZURN INDUSTRIES, LLC ♦ COMMERCIAL BRASS OPERATION ♦ 2640 SOUTH WORK STREET ♦ FALCONER NY 14733

Phone: 1-800-997-3876 ♦ Fax: 1-919-775-3541 ♦ www.zurn.com

In Canada: ZURN INDUSTRIES LIMITED ♦ 3544 Nashua Drive ♦ Mississauga, Ontario L4V1L2 ♦ Phone: 905/405-8272 Fax: 905/405-1292