



a Geberit company

2100 South Clearwater Drive
Des Plaines, IL 60018
Phone: 847-803-5000
Fax: 847-803-5454
www.chicagofaucets.com

ROUGH-IN

FITTING NO.

962-VOSCP

SUBMITTED MODEL NO.

BY: JAR

DATE: 11-01-07

CHK: *JAR*

REV:

FOR TECHNICAL ASSISTANCE
1-800-TEC-TRUE (1-800-832-8783)

SUBMITTED AS SHOWN

SUBMITTED AS NOTED

SEE ATTACHED FOR
SUBMITTED MODIFICATION

JOB NAME

ITEM NO.

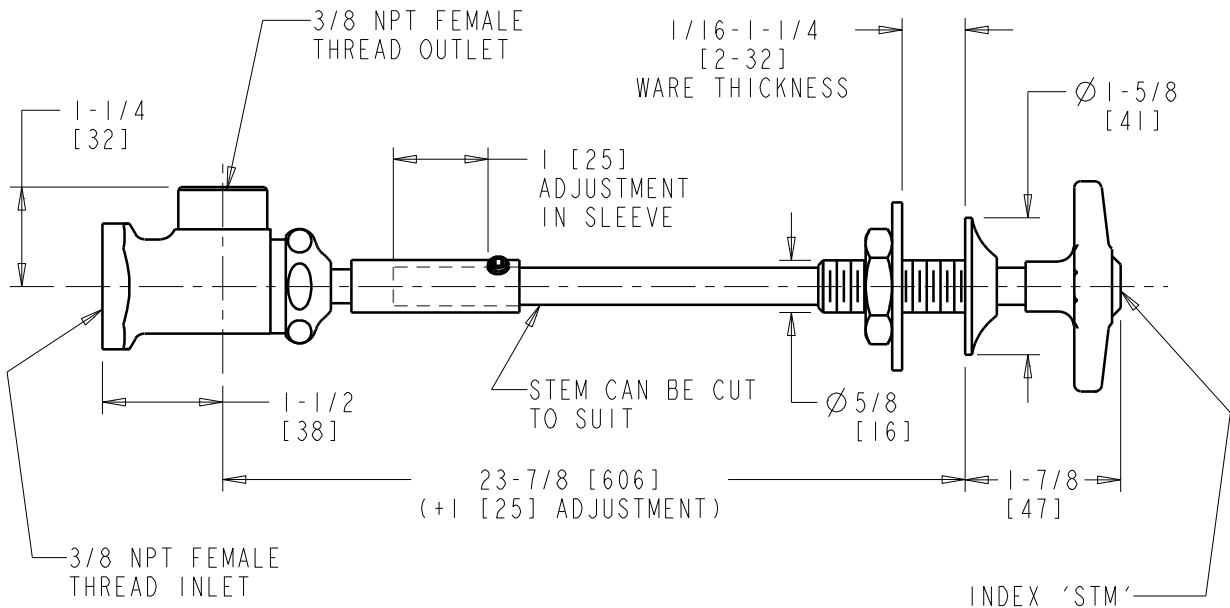

DIMENSIONS ARE IN INCHES AND [MILLIMETERS].

TECHNICAL DATA

- REMOTE CONTROL STEAM VALVE FOR STRAIGHT PANELS
- ANGLE STOP VALVE
- 204 INDEXED 4-ARM HANDLE
- 937-XST SLO-COMPRESSION OPERATING CARTRIDGE
- FINISH: CHROME PLATE

- 90° ROD GUIDE FLANGE

ROUGHING IN DIMENSIONS MAY VARY AND ARE SUBJECT TO CHANGE. NO RESPONSIBILITY IS ASSUMED FOR USE OF SUPERCEDED OR VOIDED DATA.